

# WEIDER® 125

Model No. WEBE07920

Serial No. \_\_\_\_\_

Write the serial number in the space above for future reference.

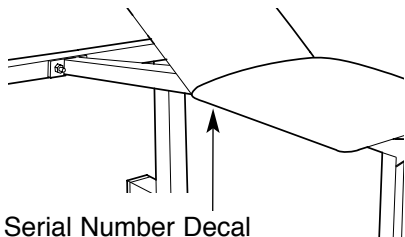

Serial Number Decal

## USER'S MANUAL

### QUESTIONS?

As a manufacturer, we are committed to providing complete customer satisfaction. If you have questions, or find that there are missing or damaged parts, we will guarantee you complete satisfaction through direct assistance from our factory.

**TO AVOID DELAYS, PLEASE CALL DIRECT TO OUR TOLL-FREE CUSTOMER HOT LINE.** The trained technicians on our customer hot line will provide immediate assistance, free of charge to you.

**CUSTOMER HOT LINE:**

**1-800-999-3756**

Mon.–Fri., 6 a.m.–6 p.m. MST

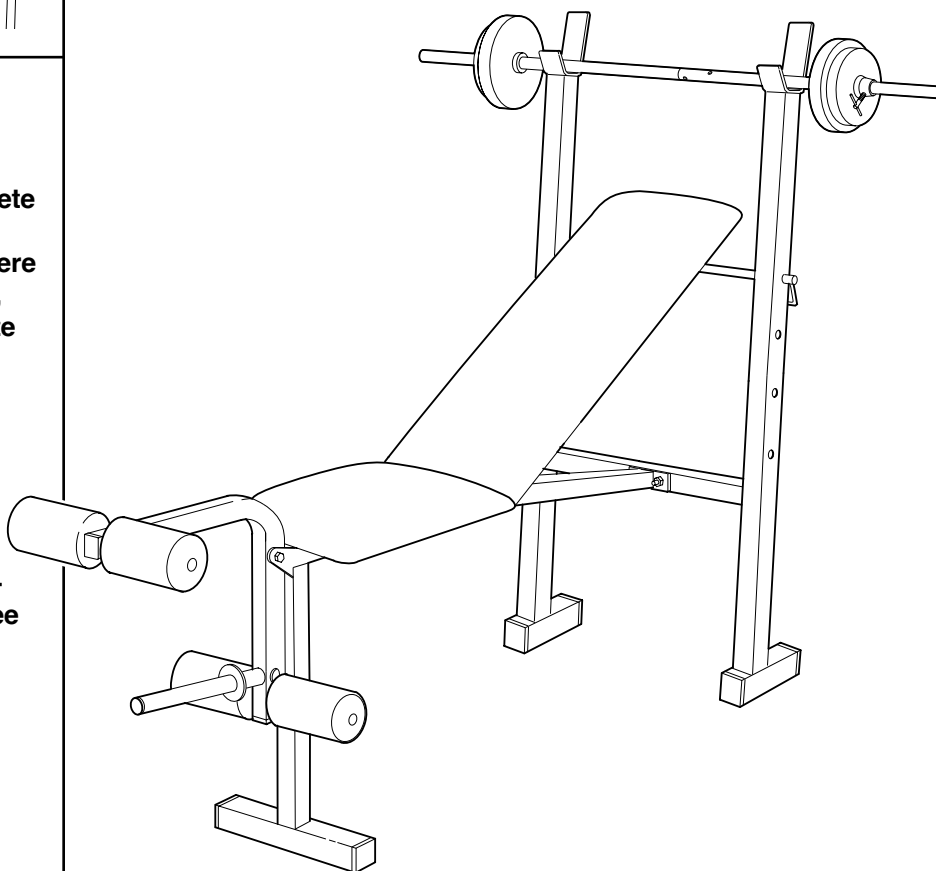

### **▲ CAUTION**

Read all precautions and instructions in this manual before using this equipment. Save this manual for future reference.

Visit our website at

[www.weiderfitness.com](http://www.weiderfitness.com)

new products, prizes,  
fitness tips, and much more!

# TABLE OF CONTENTS

WARNING DECAL PLACEMENT .....	2
IMPORTANT PRECAUTIONS .....	3
BEFORE YOU BEGIN .....	4
ASSEMBLY .....	5
ADJUSTMENTS .....	8
EXERCISE GUIDELINES .....	9
ORDERING REPLACEMENT PARTS .....	Back Cover
LIMITED WARRANTY .....	Back Cover

Note: A PART IDENTIFICATION CHART and a PART LIST/EXPLODED DRAWING are attached in the center of this manual. Remove the PART IDENTIFICATION CHART and PART LIST/EXPLODED DRAWING before beginning assembly.

## WARNING DECAL PLACEMENT

The decals shown here have been placed on the weight bench. If a decal is missing or illegible, please call our Customer Service Department toll-free at 1-800-999-3756, Monday through Friday, 6 a.m. until 6 p.m. Mountain Time, to order a free replacement decal. Apply the decal in the location shown.

**! WARNING**

- Misuse of this product may result in serious injury.
- Read user's manual and follow all warnings and operating instructions prior to use.
- Do not allow children on or around machine.
- Replace label if damaged, illegible, or removed.

**! WARNING**  
Keep hands and fingers clear of this area.

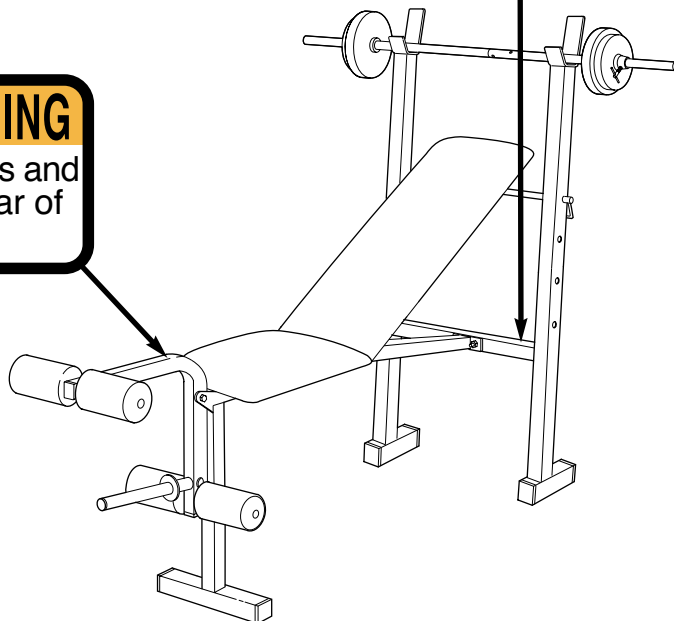

---

# IMPORTANT PRECAUTIONS

**⚠ WARNING:** To reduce the risk of serious injury, read the following important precautions before using the weight bench.

1. Read all instructions in this manual before using the weight bench. Use the weight bench only as described in this manual.
2. It is the responsibility of the owner to ensure that all users of the weight bench are adequately informed of all precautions.
3. The weight bench is intended for home use only. Do not use the weight bench in any commercial, rental, or institutional setting.
4. Use the weight bench only on a level surface. Cover the floor beneath the weight bench to protect the floor.
5. Make sure that all parts are properly tightened each time you use the weight bench. Replace any worn parts immediately.
6. Keep children under the age of 12 and pets away from the weight bench at all times.
7. Always wear athletic shoes for foot protection while exercising.
8. Never use the barbell if the roll pins become loose or broken. Do not use a barbell that is longer than five feet with the weight bench.
9. Keep hands and feet away from moving parts.
10. The weight bench is designed to support a maximum user weight of 300 pounds. Do not use the barbell with more than 100 pounds. Do not place more than 110 pounds, including the barbell and weights, on the weight rests. Do not place more than 50 pounds on the leg lever.
11. When you are using the leg lever, place a barbell with the same amount of weight on the weight rests to balance the bench.
12. Always make sure there is an equal amount of weight on each side of your barbell when you are using it. When adding or removing weights, always keep some weight on both ends of the barbell to prevent the barbell from tipping.
13. When using the backrest in an inclined position, make sure that the support rod is inserted completely through the uprights and turned to the locked position.
14. If you feel pain or dizziness at any time while exercising, stop immediately and begin cooling down.

**⚠ WARNING:** Before beginning this or any exercise program, consult your physician. This is especially important for persons over the age of 35 or persons with pre-existing health problems. Read all instructions before using. ICON assumes no responsibility for personal injury or property damage sustained by or through the use of this product.

# BEFORE YOU BEGIN

Thank you for selecting the WEIDER® 125 weight bench. The versatile WEIDER® 125 weight bench is designed to develop every major muscle group of the body. Whether your goal is a shapely figure, dramatic muscle size and strength, or a healthier cardiovascular system, the WEIDER® 125 weight bench will help you to achieve the specific results you want.

**For your benefit, read this manual carefully before using the weight bench.** If you have additional questions, please call our Customer Service Department

toll-free at 1-800-999-3756, Monday through Friday, 6 a.m. until 6 p.m. Mountain Time (excluding holidays). To help us assist you, please note the product model number and serial number before calling. The model number is WEBE07920. The serial number can be found on a decal attached to the weight bench (see the front cover of this manual).

Before reading further, please look at the drawing below and familiarize yourself with the parts that are labeled.

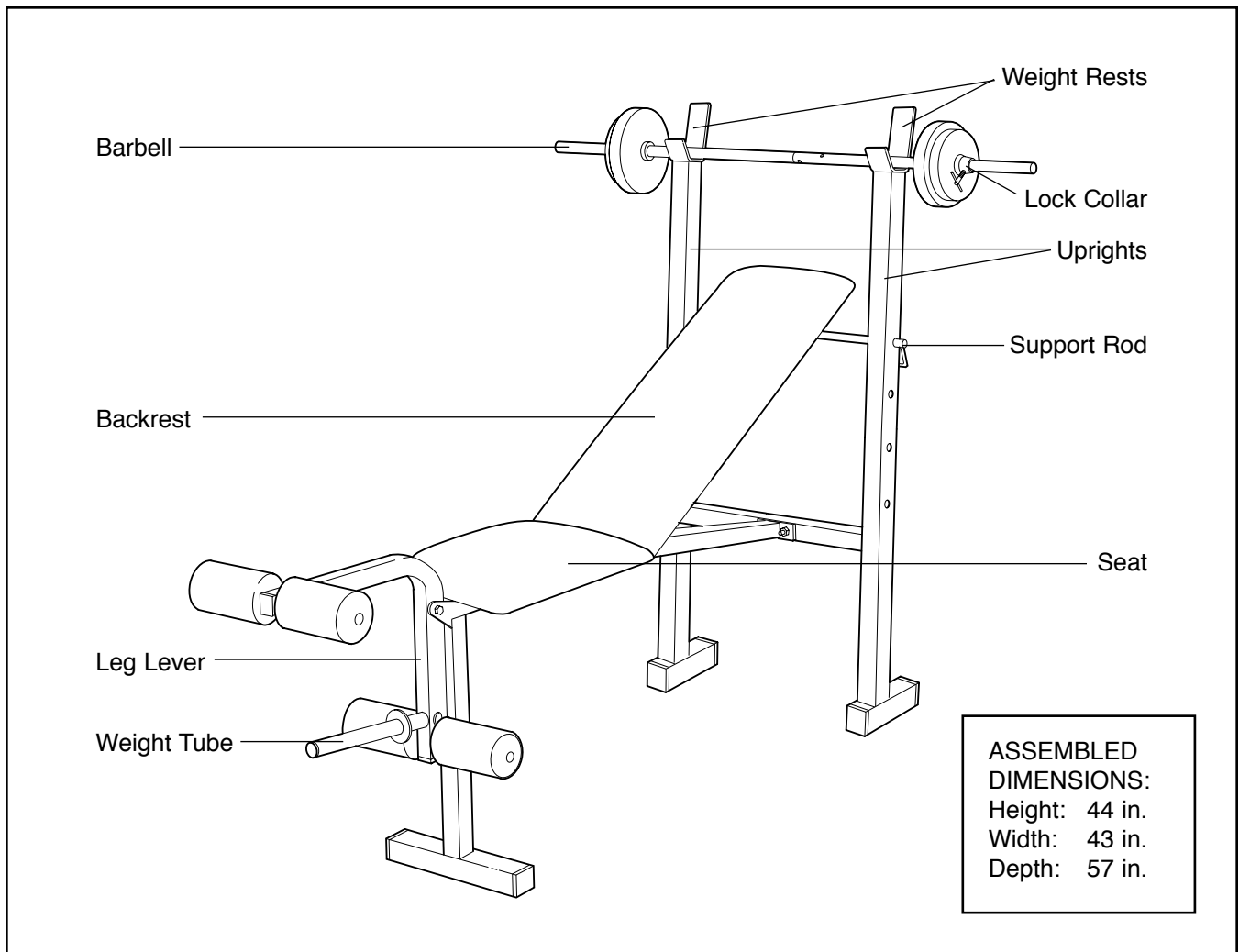

# ASSEMBLY

## Make Things Easier for Yourself





This manual is designed to ensure that the weight bench can be assembled successfully by anyone. Most people find that by setting aside plenty of time, assembly will go smoothly.

**Before beginning assembly, carefully read the following information and instructions:**

- Assembly requires two people.
- For help identifying small parts refer to the PART IDENTIFICATION CHART.
- Tighten all parts as you assemble them, unless instructed to do otherwise.
- Place all parts in a cleared area and remove the packing materials. Do not dispose of the packing materials until assembly is completed.

- As you assemble the weight bench, make sure all parts are oriented as shown in the drawings.

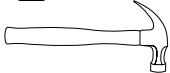
**The following tools (not included) are required for assembly:**

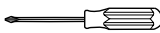
- **Two adjustable wrenches** 
- **One rubber mallet** 
- **One hammer** 
- **One standard screwdriver** 
- **One Phillips screwdriver** 
- **Lubricant, such as grease or petroleum jelly, and soapy water.**

Assembly will be more convenient if you have a socket set, a set of open-end or closed-end wrenches, or a set of ratchet wrenches.

1. **Before assembling this weight bench, be sure that you have read and understand the information in the box above.**

Tap two 38mm Square Inner Caps (21) into each Upright (1).

Attach the Crossbar (3) to the Uprights (1) with four M8 x 55mm Bolts (14), four M8 Washers (12), and four M8 Nylon Locknuts (13). **Be sure that the Crossbar and Uprights are oriented as shown. The decal must be facing up and the high side of the weight rests must be on the same side. Do not tighten the Locknuts yet.**

2. Tap two 30mm Square Inner Caps (22) into the Front Leg (8).

Attach the Front Leg (8) to the Frame (2) with the M10 x 20mm Bolt (17).

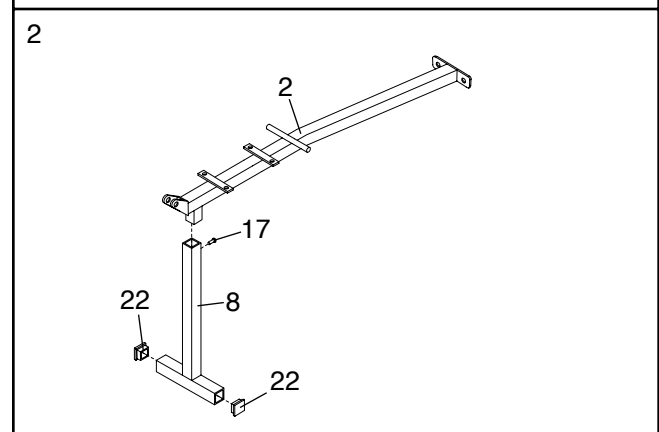
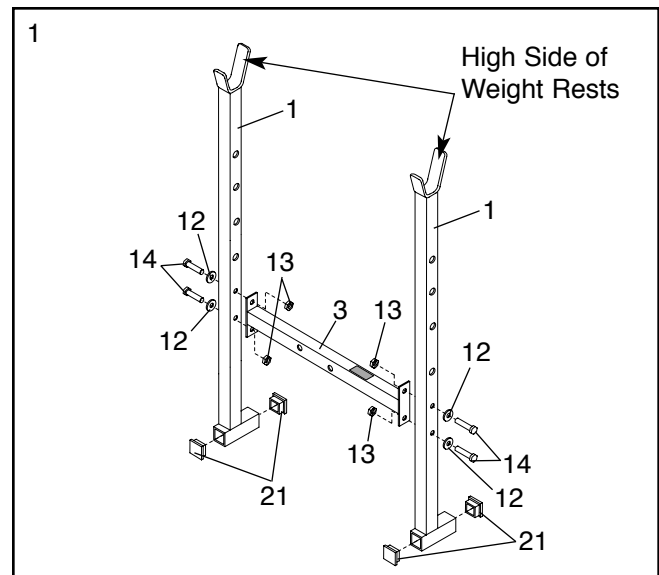

3. **Be sure that the Uprights (1) are oriented as shown; the high side of the weight rests must be on the side indicated.** Attach the Frame (2) to the Crossbar (3) with two M8 x 55mm Bolts (14), two M8 Washers (12), and two M8 Nylon Locknuts (13). **Do not tighten the Locknut yet.**

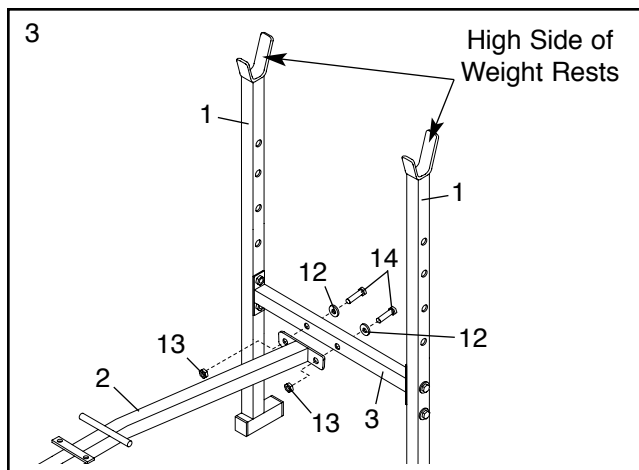

4. Tap a 30mm Square Inner Cap (22) into each end of the Leg Lever (4).

Tap a 25mm Round Inner Cap (24) into the indicated end of the weight tube. Tap the 1" Angled Round Cap (20) onto the other end of the weight tube.

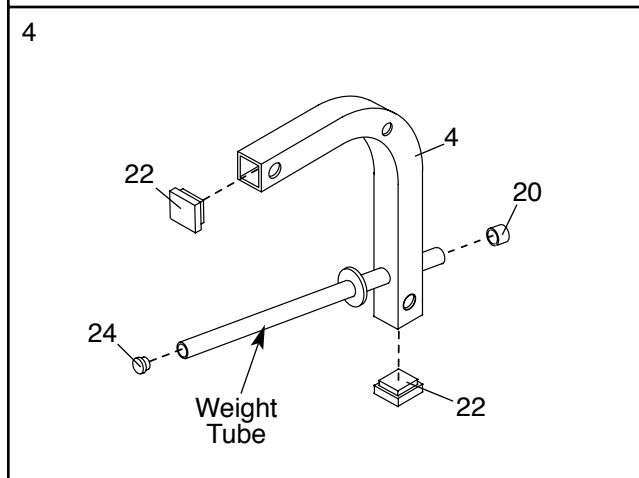

5. Lubricate the M10 x 60mm Bolt (18). Attach the Leg Lever (4) to the Frame (2) with the Bolt and the M10 Nylon Locknut (19). **Do not overtighten the Locknut; the Leg Lever must be able to pivot easily.**

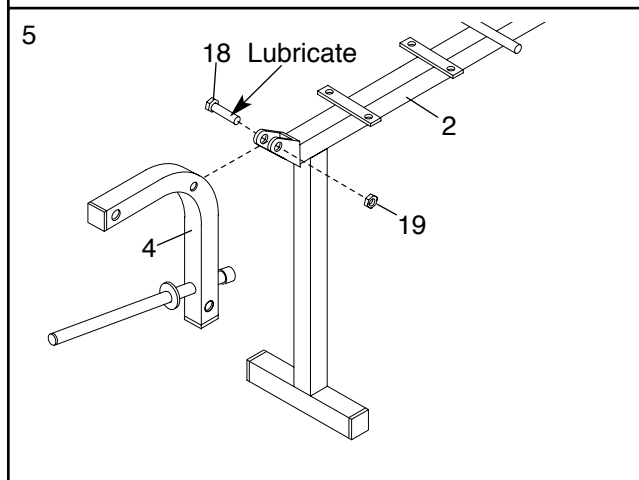

6. Tap two 19mm Round Inner Caps (9) into each Pad Tube (10). Insert the Pad Tubes into the holes in the Leg Lever (4). Slide two Foam Pads (23) onto each Pad Tube.

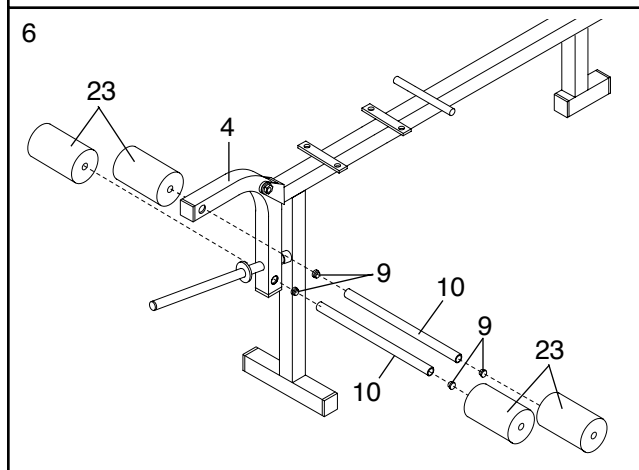

- Press four 25.4mm Square Inner Cap (25) into the ends of the Backrest Tubes (5).

Attach one Backrest Tube (5) to the Backrest (6) with two M6 x 38mm Screws (16) and two M6 Washers (26). Attach the other Backrest Tube to the Backrest with one M6 x 38mm Screw and one M6 Washer. **Note: Do not tighten the three Screws yet. A fourth M6 x 38mm Screw will be attached at the end of step 8.**

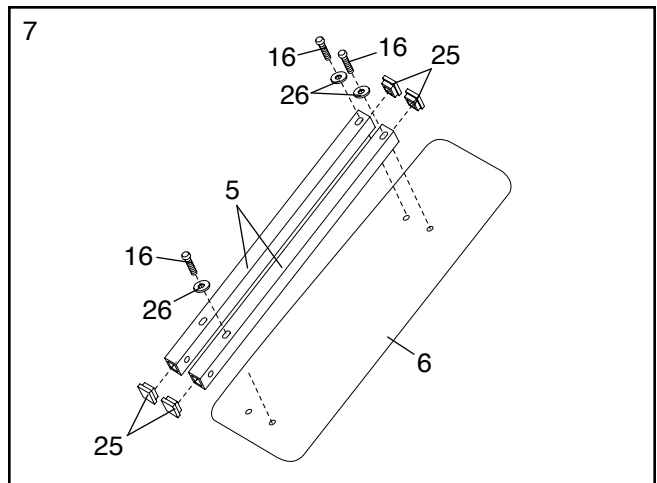

- Tap a 19mm Round Inner Cap (9) into each end of the Support Rod (7). Insert the Support Rod through one of the three sets of holes in the Uprights (1). Rotate the Support Rod to the locked position, with the end of the Support Rod clipped onto the Upright.

**See the inset drawing.** Slide the ends of both Backrest Tubes (5) onto the pin on the Frame (2). Attach the free end of the Backrest Tube (5) to the Backrest (6) with an M6 x 38mm Screw (16) and an M6 Washer (26). **Fully tighten all four M6 x 38mm Screws.**

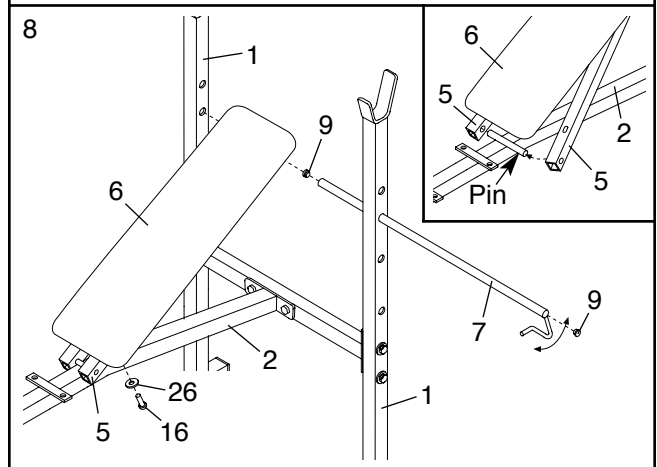

**Tighten the M8 Nylon Locknuts (13) used in steps 1 and 3.**

- Attach the Seat (11) to the brackets on the Frame (2) with four M6 x 16mm Screws (15) and four M6 Washers (26).

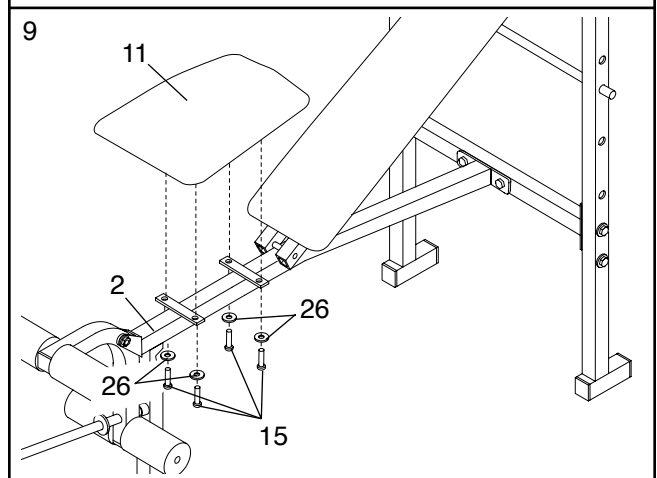

- Insert the Inner Bar (29) into the Outer Bar (30) and align the indicated holes. Using a hammer, tap the two Roll Pins (31) into the holes until they are flush with the Outer Bar.

Press two 25mm Round Inner Caps (24) into the ends of the Inner and Outer Bars (29, 30).

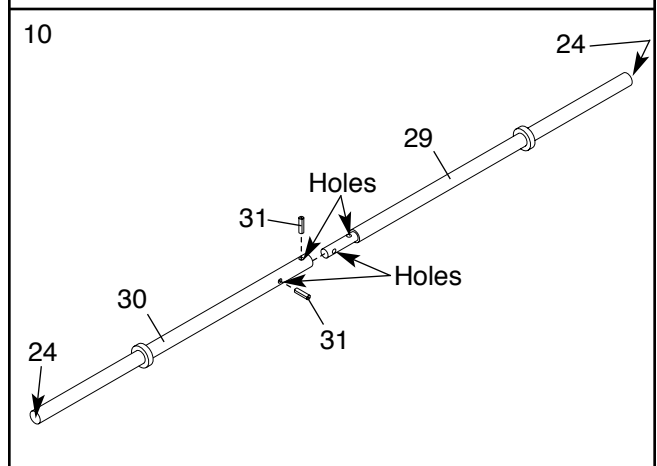

- Make sure that all parts are properly tightened before you use the weight bench. The use of all remaining parts will be explained in ADJUSTMENTS starting on the next page.**

# ADJUSTMENTS

The steps below explain how the weight bench can be adjusted. See EXERCISE GUIDELINES on page 9 for important exercise information and refer to the accompanying exercise guide to see the correct form for each exercise.

Make sure all parts are properly tightened each time the weight bench is used. Replace any worn parts immediately. The weight bench can be cleaned with a damp cloth and a mild, non-abrasive detergent. Do not use solvents.

## ADJUSTING THE BACKREST

The Backrest (6) can be used in a declined position, a level position, or three inclined positions. To use the Backrest in the declined position, remove the Support Rod (7) and lay the Backrest on the Frame (2).

To use the Backrest (6) in a level position, first lift the Backrest. Insert the Support Rod (7) through the bottom set of holes in the Uprights (1). Rotate the Support Rod to the locked position, with the end of the Support Rod clipped onto the Upright. Rest the Backrest on the Support Rod.

To use the Backrest (6) in an inclined position, first lift the Backrest. Insert the Support Rod (7) through one of the three sets of holes in the Uprights (1). Rotate the Support Rod to the locked position, with the end of the Support Rod clipped onto the Upright. Rest the Backrest on the Support Rod.

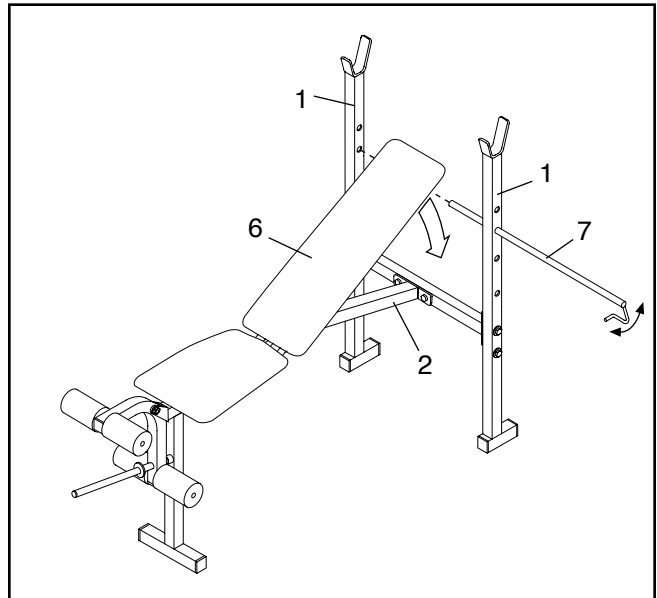

## ATTACHING WEIGHTS TO THE LEG LEVER

To use the Leg Lever (4), slide the desired Weights (27, 28) onto the weight tube.

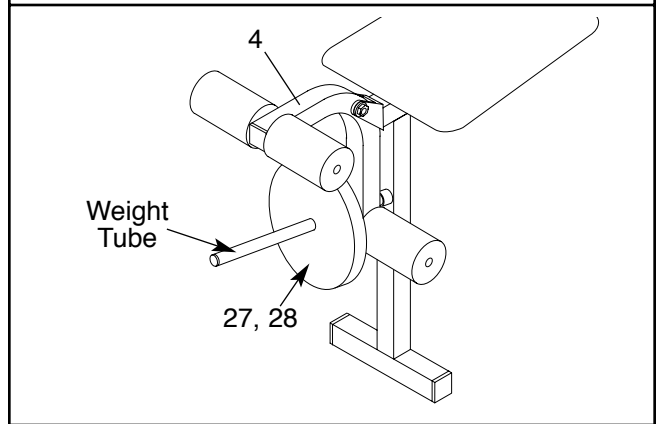

## ATTACHING WEIGHTS TO THE BARBELL

Slide an equal amount of Weight (27, 28) onto each end of the barbell. Slide the two Lock Collars (32) against the Weights, and tighten them fully.

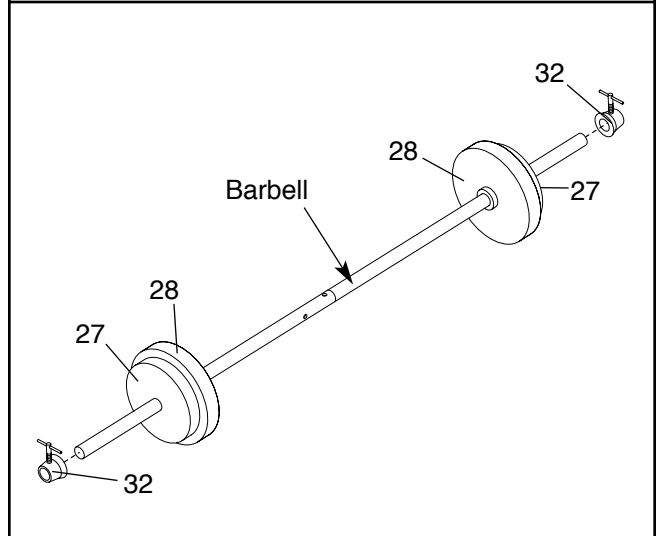

**WARNING:** Do not place more than 50 pounds on the Leg Lever (9).

**WARNING:** Always secure the Weights (27, 28) on the barbell with the Lock Collars (32). Never use the barbell with more than 100 pounds.



---

# EXERCISE GUIDELINES

## THE FOUR BASIC TYPES OF WORKOUTS

### Muscle Building

To increase the size and strength of your muscles, push them close to their maximum capacity. Your muscles will continually adapt and grow as you progressively increase the intensity of your exercise. You can adjust the intensity level of an individual exercise in two ways:

- by changing the amount of weight used
- by changing the number of repetitions or sets performed. (A “repetition” is one complete cycle of an exercise, such as one sit-up. A “set” is a series of repetitions.)

The proper amount of weight for each exercise depends upon the individual user. You must gauge your limits and select the amount of weight that is right for you. Begin with 3 sets of 8 repetitions for each exercise you perform. Rest for 3 minutes after each set. When you can complete 3 sets of 12 repetitions without difficulty, increase the amount of weight.

### Toning

You can tone your muscles by pushing them to a moderate percentage of their capacity. Select a moderate amount of weight and increase the number of repetitions in each set. Complete as many sets of 15 to 20 repetitions as possible without discomfort. Rest for 1 minute after each set. Work your muscles by completing more sets rather than by using high amounts of weight.

### Weight Loss

To lose weight, use a low amount of weight and increase the number of repetitions in each set. Exercise for 20 to 30 minutes, resting for a maximum of 30 seconds between sets.

### Cross Training

Cross training is an efficient way to get a complete and well-balanced fitness program. An example of a balanced program is:

- Plan weight training workouts on Monday, Wednesday, and Friday.
- Plan 20 to 30 minutes of aerobic exercise, such as cycling or swimming, on Tuesday and Thursday.
- Rest from both weight training and aerobic exercise for at least one full day each week to give your body time to regenerate.

The combination of weight training and aerobic exercise will reshape and strengthen your body, plus develop your heart and lungs.

## PERSONALIZING YOUR EXERCISE PROGRAM

Determining the exact length of time for each workout, as well as the number of repetitions or sets completed, is an individual matter. It is important to avoid overdoing it during the first few months of your exercise program. You should progress at your own pace and be sensitive to your body’s signals. If you experience pain or dizziness at any time while exercising, stop immediately and begin cooling down. Find out what is wrong before continuing. Remember that adequate rest and a proper diet are important factors in any exercise program.

### WARMING UP

Begin each workout with 5 to 10 minutes of stretching and light exercise to warm up. Warming up prepares your body for more strenuous exercise by increasing circulation, raising your body temperature and delivering more oxygen to your muscles.

### WORKING OUT

Each workout should include 6 to 10 different exercises. Select exercises for every major muscle group, emphasizing areas that you want to develop most. To give balance and variety to your workouts, vary the exercises from session to session.

Schedule your workouts for the time of day when your energy level is the highest. Each workout should be followed by at least one day of rest. Once you find the schedule that is right for you, stick with it.

### EXERCISE FORM

Maintaining proper form is an essential part of an effective exercise program. This requires moving through the full range of motion for each exercise, and moving only the appropriate parts of the body. Exercising in an uncontrolled manner will leave you feeling exhausted. On the exercise guide accompanying this manual you will find photographs showing the correct form for several exercises, and a list of the muscles affected. Refer to the muscle chart on page 10 to find the names of the muscles.

The repetitions in each set should be performed smoothly and without pausing. The exertion stage of each repetition should last about half as long as the return stage. Proper breathing is important. Exhale during the exertion stage of each repetition and inhale during the return stroke. Never hold your breath.

Rest for a short period of time after each set. The ideal resting periods are:

- Rest for three minutes after each set for a muscle building workout.
- Rest for one minute after each set for a toning workout.
- Rest for 30 seconds after each set for a weight loss workout.

Plan to spend the first couple of weeks familiarizing yourself with the equipment and learning the proper form for each exercise.

### COOLING DOWN

End each workout with 5 to 10 minutes of stretching. Include stretches for both your arms and legs. Move

slowly as you stretch and do not bounce. Ease into each stretch gradually and go only as far as you can without strain. Stretching at the end of each workout is an effective way to increase flexibility.

### STAYING MOTIVATED

For motivation, keep a record of each workout. The chart on page 11 of this manual can be photocopied and used to schedule and record your workouts. List the date, the exercises performed, the weight used, and the numbers of sets and repetitions completed. Record your weight and key body measurements at the end of every month. Remember, the key to achieving the greatest results is to make exercise a regular and enjoyable part of your everyday life.

### MUSCLE CHART

- A. Sternomastoid (neck)
- B. Pectoralis Major (chest)
- C. Biceps (front of arm)
- D. Obliques (waist)
- E. Brachioradials (forearm)
- F. Hip Flexors (upper thigh)
- G. Abductor (outer thigh)
- H. Quadriceps (front of thigh)
- I. Sartorius (front of thigh)
- J. Tibialis Anterior (front of calf)
- K. Soleus (front of calf)
- L. Rectus Abdominus (stomach)
- M. Adductor (inner thigh)
- N. Trapezius (upper back)
- O. Rhomboideus (upper back)
- P. Deltoid (shoulder)
- Q. Triceps (back of arm)
- R. Latissimus Dorsi (mid back)
- S. Spinae Erectors (lower back)
- T. Gluteus Medius (hip)
- U. Gluteus Maximus (buttocks)
- V. Hamstring (back of leg)
- W. Gastrocnemius (back of calf)

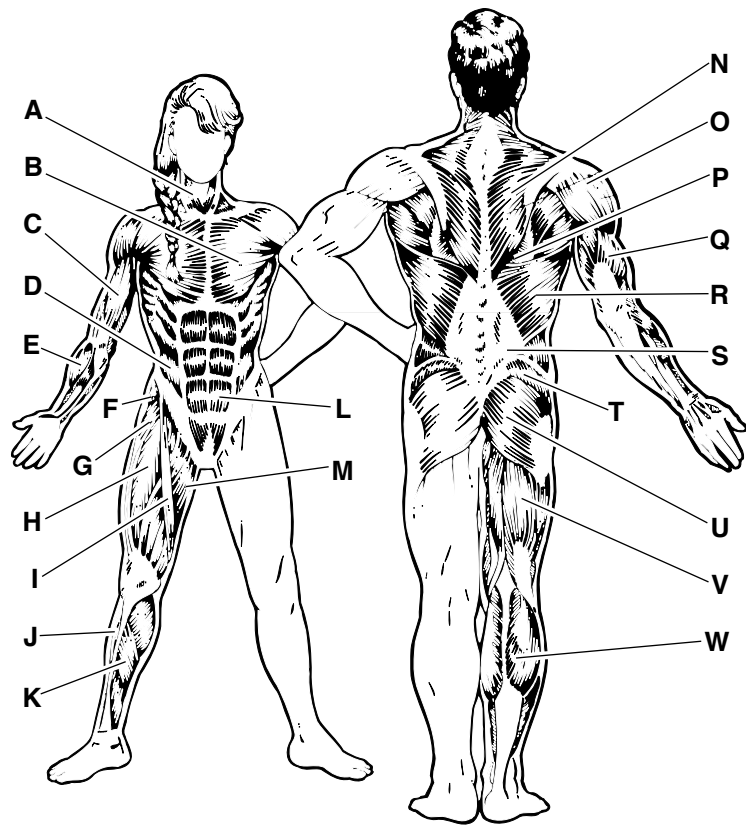

<b>MONDAY</b>	<b>EXERCISE</b>	<b>WEIGHT</b>	<b>SETS</b>	<b>REPS</b>
Date: / /				

**TUESDAY AEROBIC EXERCISE**

Date: / /

<b>WEDNESDAY</b>	<b>EXERCISE</b>	<b>WEIGHT</b>	<b>SETS</b>	<b>REPS</b>
Date: / /				

**THURSDAY AEROBIC EXERCISE**

Date: / /

<b>FRIDAY</b>	<b>EXERCISE</b>	<b>WEIGHT</b>	<b>SETS</b>	<b>REPS</b>
Date: / /				

Make photocopies of this page for scheduling and recording your workouts.

---

## ORDERING REPLACEMENT PARTS

To order replacement parts, simply call our Customer Service Department toll-free at 1-800-999-3756, Monday through Friday, 6 a.m. until 6 p.m. Mountain Time (excluding holidays). To help us assist you, please be prepared to give the following information when calling:

- The MODEL NUMBER of the product (WEBE07920)
- The NAME of the product (WEIDER® 125 weight bench)
- The SERIAL NUMBER of the product (see the front cover of this manual)
- The KEY NUMBER and DESCRIPTION of the desired part(s) (see the PART LIST and EXPLODED DRAWING in the center of this manual)

---

## LIMITED WARRANTY

ICON Health & Fitness, Inc. (ICON), warrants this product to be free from defects in workmanship and material, under normal use and service conditions, for a period of ninety (90) days from the date of purchase. This warranty extends only to the original purchaser. ICON's obligation under this warranty is limited to replacing or repairing, at ICON's option, the product through one of its authorized service centers. All repairs for which warranty claims are made must be pre-authorized by ICON. This warranty does not extend to any product or damage to a product caused by or attributable to freight damage, abuse, misuse, improper or abnormal usage or repairs not provided by an ICON authorized service center; products used for commercial or rental purposes; or products used as store display models. No other warranty beyond that specifically set forth above is authorized by ICON.

ICON is not responsible or liable for indirect, special or consequential damages arising out of or in connection with the use or performance of the product or damages with respect to any economic loss, loss of property, loss of revenues or profits, loss of enjoyment or use, costs of removal or installation or other consequential damages of whatsoever nature. Some states do not allow the exclusion or limitation of incidental or consequential damages. Accordingly, the above limitation may not apply to you.

The warranty extended hereunder is in lieu of any and all other warranties and any implied warranties of merchantability or fitness for a particular purpose is limited in its scope and duration to the terms set forth herein. Some states do not allow limitations on how long an implied warranty lasts. Accordingly, the above limitation may not apply to you.

This warranty gives you specific legal rights. You may also have other rights which vary from state to state.

**ICON HEALTH & FITNESS, INC., 1500 S. 1000 W., LOGAN, UT 84321-9813**

**REMOVE THIS PART IDENTIFICATION CHART  
PART LIST/EXPLODED DRAWING**

**SAVE THIS PART IDENTIFICATION CHART  
PART LIST/EXPLODED DRAWING FOR FUTURE REFERENCE**

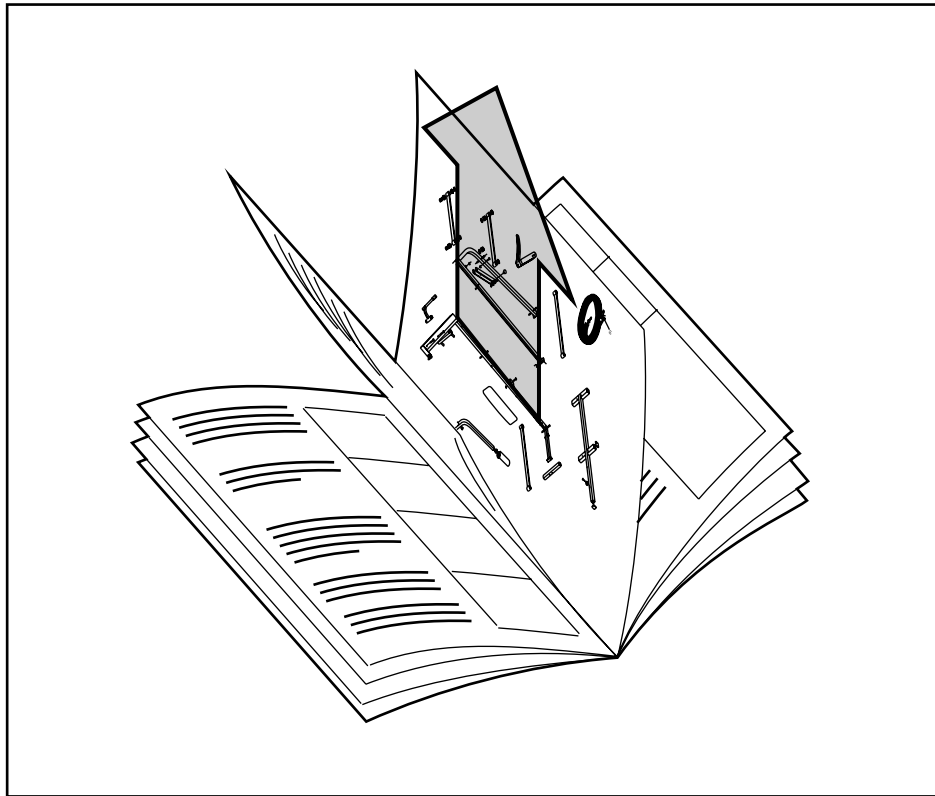

# PART IDENTIFICATION CHART

This chart is provided to help you identify the small parts used in assembly. The number in parenthesis below each part refers to the key number of the part, from the PART LIST in the center of this manual. **Important:** Some parts may have been pre-assembled for shipping purposes. If you cannot find a part in the parts bags, check to see if it has been pre-assembled.

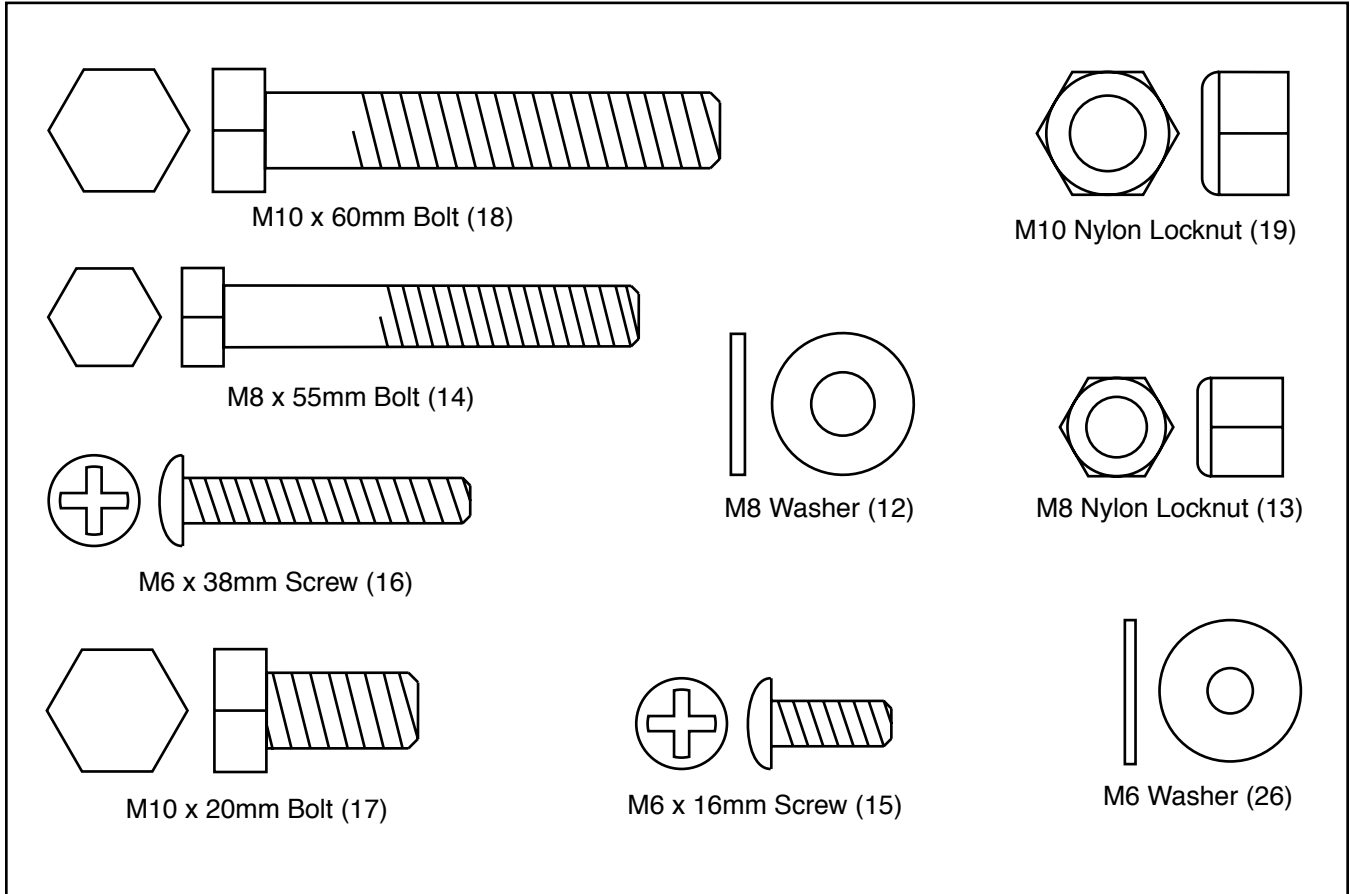

# EXPLODED DRAWING—Model No. WEBE07920

R1002A

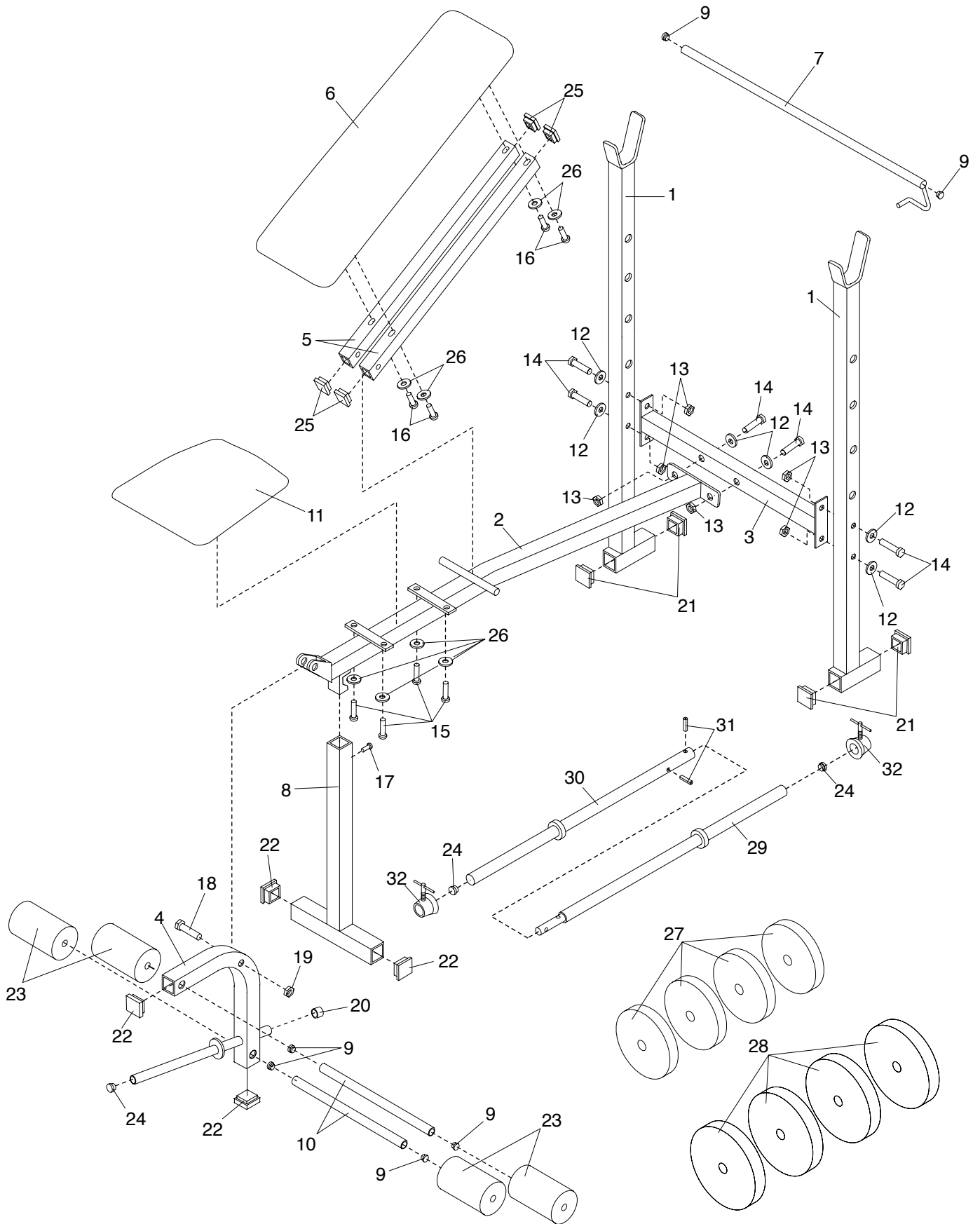

# PART LIST—Model No. WEBE07920

R1002A

Key No.	Qty.	Description	Key No.	Qty.	Description
1	2	Upright	18	1	M10 x 60mm Bolt
2	1	Frame	19	1	M10 Nylon Locknut
3	1	Crossbar	20	1	25mm Angled Round Cap
4	1	Leg Lever	21	4	38mm Square Inner Cap
5	2	Backrest Tube	22	4	30mm Square Inner Cap
6	1	Backrest	23	4	Foam Pad
7	1	Support Rod	24	3	25mm Round Inner Cap
8	1	Front Leg	25	4	25.4mm Square Inner Cap
9	6	19mm Round Inner Cap	26	8	M6 Washer
10	2	Pad Tube	27	4	10-pound Weight
11	1	Seat	28	4	15-pound Weight
12	6	M8 Washer	29	1	Inner Bar
13	6	M8 Nylon Locknut	30	1	Outer Bar
14	6	M8 x 55mm Bolt	31	2	Roll Pin
15	4	M6 x 16mm Screw	32	2	Lock Collar
16	4	M6 x 38mm Screw	#	1	User's Manual
17	1	M10 x 20mm Bolt	#	1	Exercise Guide

"#" Indicates a non-illustrated part. Specifications are subject to change without notice. See the back cover of this manual for information about ordering replacement parts.